

# Fahrertriebe FG-Reihe

## Kranfahrertrieb FG-Reihe, Typ FGA 422 / 423

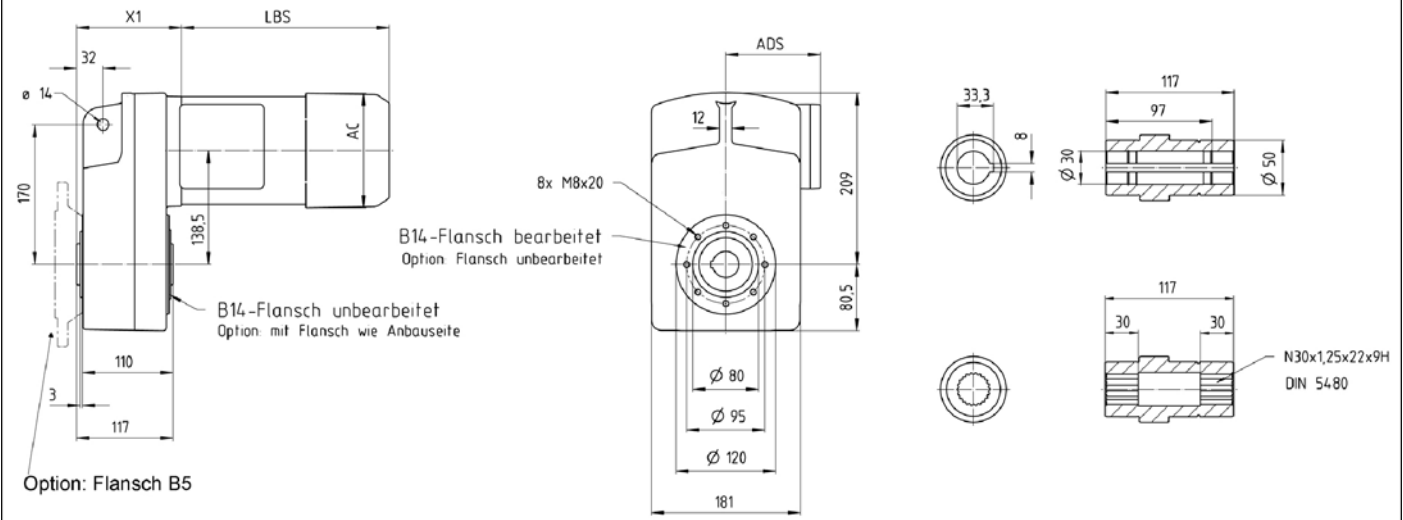

### Abmessungen [mm]:

Getriebe	Motor	X1	AC	ADS	LBSEFB	LBSZFB
FGA422 2-stufig und FGA423 3-stufig	D63	128,5	124	107	189,5	218
	D71	127,5	139	116	212,5	227
	KD71				252,5	267
	D80	136,5	158	123	239	266,5
	KD80				276	303,5
	D90S	136,5	177	134	268	288,5
	KD90S				308	328,5
	D90L	136,5	177	134	293	313,5
	KD90L				333	353,5
	D100L	161,5	196	142	332,5	372
KD100L	362				401,5	

### Untersetzungen:

FGA422	2-stufig	6,96	8,46	9,05	10,4	12,0	15,2	17,6	19,0	21,2	24,6	30,0	33,5
FGA423	3-stufig	38,9	45,3	48,8	56,1	64,3	70,0	82,7	90,5	104	127	145	166

### Optionen (andere auf Anfrage):

→ B5 Flansch Ø 200 mm
→ Zahnabe N30x1,25x22x9H (DIN5480)
→ Hohlwelle Ø 35 mm

# Fahrertriebe FG-Reihe

## Kranfahrertrieb FG-Reihe, Typ FGA 1353

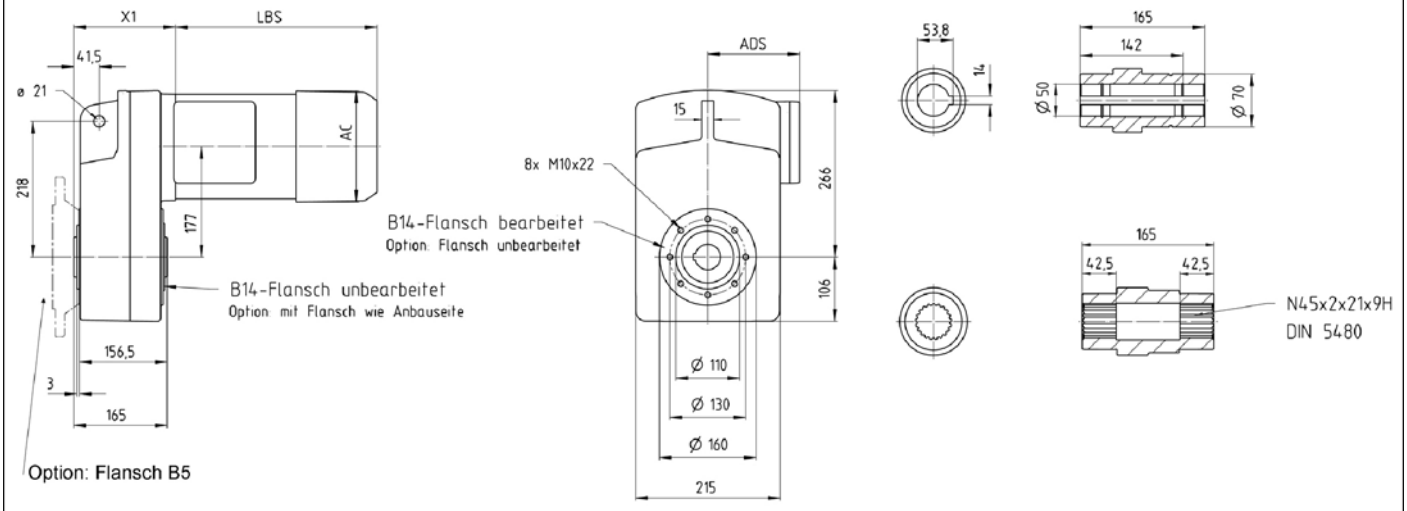

Abmessungen [mm]:										
Getriebe	Motor	X1	AC	ADS	LBSEFB	LBSZFB				
FGA 1353 3-stufig	D71	156	139	116	212,5	227				
	KD71				252,5	267				
	D80	165	158	123	239	266,5				
	KD80				276	303,5				
	D90S	165	177	134	268	288,5				
	KD90S				308	328,5				
	D90L	165	177	134	293	313,5				
	KD90L				333	353,5				
	D100L	190	196	142	332,5	372				
	KD100L				362	401,5				
Untersetzungen:										
FGA1353	3-stufig	37,40	43,69	53,44	70,9	91,75	110,3	136,7	166,8	217,4
Optionen (anderes auf Anfrage):										
→ B5 Flansch ø 250 mm										
→ Zahnabe N45x2x21x9H (DIN 5480)										
→ Hohlwelle ø 55 mm										